

© International Baccalaureate Organization 2022

All rights reserved. No part of this product may be reproduced in any form or by any electronic or mechanical means, including information storage and retrieval systems, without the prior written permission from the IB. Additionally, the license tied with this product prohibits use of any selected files or extracts from this product. Use by third parties, including but not limited to publishers, private teachers, tutoring or study services, preparatory schools, vendors operating curriculum mapping services or teacher resource digital platforms and app developers, whether fee-covered or not, is prohibited and is a criminal offense.

More information on how to request written permission in the form of a license can be obtained from <https://ibo.org/become-an-ib-school/ib-publishing/licensing/applying-for-a-license/>.

© Organisation du Baccalauréat International 2022

Tous droits réservés. Aucune partie de ce produit ne peut être reproduite sous quelque forme ni par quelque moyen que ce soit, électronique ou mécanique, y compris des systèmes de stockage et de récupération d'informations, sans l'autorisation écrite préalable de l'IB. De plus, la licence associée à ce produit interdit toute utilisation de tout fichier ou extrait sélectionné dans ce produit. L'utilisation par des tiers, y compris, sans toutefois s'y limiter, des éditeurs, des professeurs particuliers, des services de tutorat ou d'aide aux études, des établissements de préparation à l'enseignement supérieur, des fournisseurs de services de planification des programmes d'études, des gestionnaires de plateformes pédagogiques en ligne, et des développeurs d'applications, moyennant paiement ou non, est interdite et constitue une infraction pénale.

Pour plus d'informations sur la procédure à suivre pour obtenir une autorisation écrite sous la forme d'une licence, rendez-vous à l'adresse <https://ibo.org/become-an-ib-school/ib-publishing/licensing/applying-for-a-license/>.

© Organización del Bachillerato Internacional, 2022

Todos los derechos reservados. No se podrá reproducir ninguna parte de este producto de ninguna forma ni por ningún medio electrónico o mecánico, incluidos los sistemas de almacenamiento y recuperación de información, sin la previa autorización por escrito del IB. Además, la licencia vinculada a este producto prohíbe el uso de todo archivo o fragmento seleccionado de este producto. El uso por parte de terceros —lo que incluye, a título enunciativo, editoriales, profesores particulares, servicios de apoyo académico o ayuda para el estudio, colegios preparatorios, desarrolladores de aplicaciones y entidades que presten servicios de planificación curricular u ofrezcan recursos para docentes mediante plataformas digitales—, ya sea incluido en tasas o no, está prohibido y constituye un delito.

En este enlace encontrará más información sobre cómo solicitar una autorización por escrito en forma de licencia: <https://ibo.org/become-an-ib-school/ib-publishing/licensing/applying-for-a-license/>.

Biology
Higher level
Paper 1

Friday 28 October 2022 (morning)

1 hour

Instructions to candidates

- Do not open this examination paper until instructed to do so.
- Answer all the questions.
- For each question, choose the answer you consider to be the best and indicate your choice on the answer sheet provided.
- The maximum mark for this examination paper is **[40 marks]**.

1. The diagram shows a prokaryotic cell.

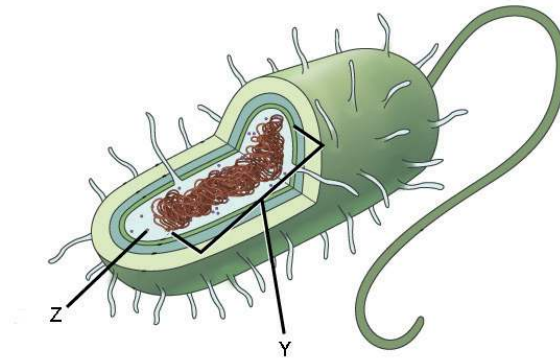

What are the structures labelled Y and Z?

	Y	Z
A.	Nucleus	70S ribosome
B.	Nucleoid	80S ribosome
C.	Nucleus	80S ribosome
D.	Nucleoid	70S ribosome

2. The micrograph shows some onion (*Allium cepa*) cells undergoing mitosis.

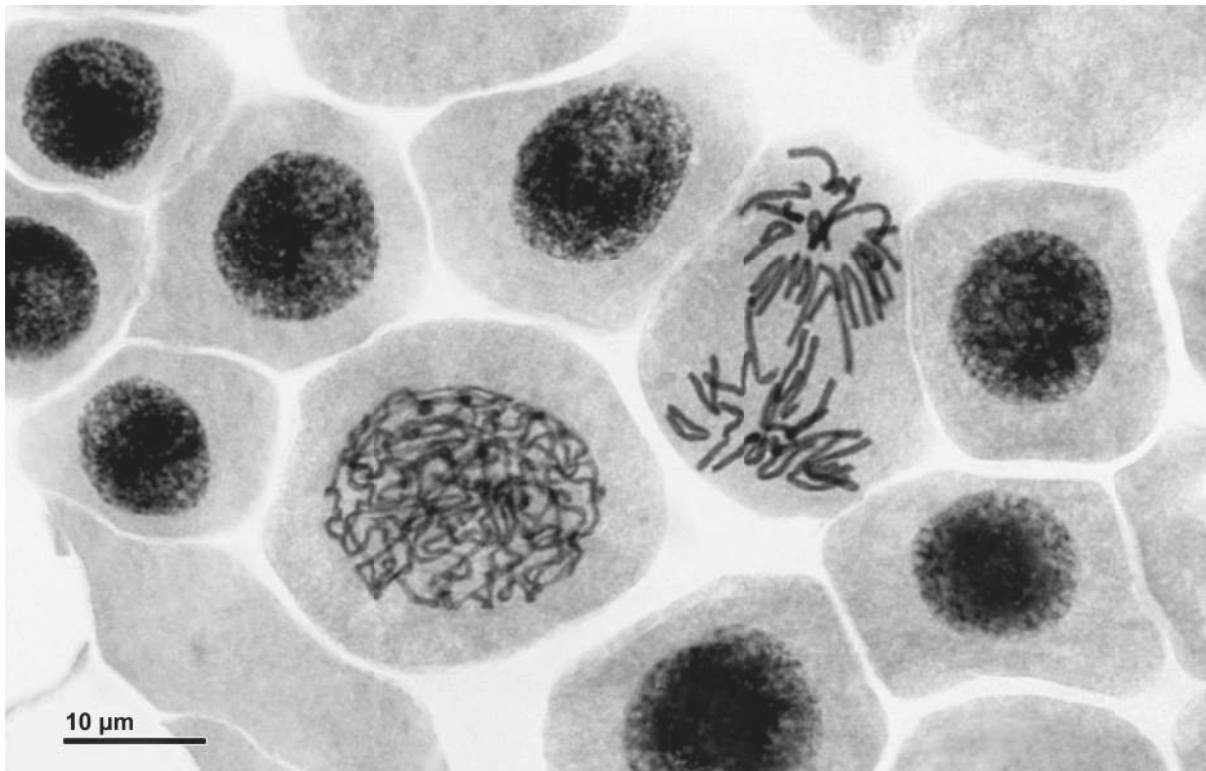

What is the mitotic index, taking into account all visible nuclei?

- A. 0.1
- B. 0.2
- C. 0.4
- D. 0.6

Turn over

3. In 1925, Gorter and Grendel carried out an experiment to study the structure of cell membranes in different mammals. The total surface area of red blood cells was measured in a sample and compared to the surface area formed by a single layer of lipid extracted from cell membranes and floated on water.

Source of red blood cell samples	Total surface area of single layer of extracted lipid on water / arbitrary units	Total surface area of membrane on red blood cells / arbitrary units
Dog	62.0	31.0
Goat	6.8	3.4
Rabbit	9.8	4.9

Which diagram best illustrates Gorter and Grendel's conclusion drawn from this experiment?

A.

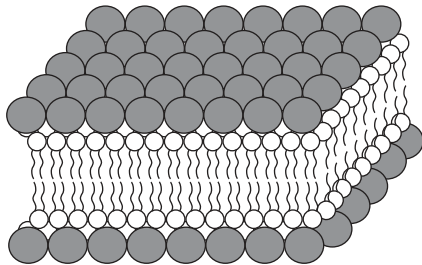

B.



C.

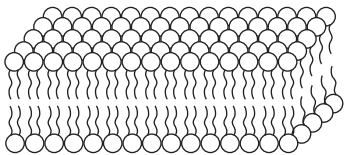

D.

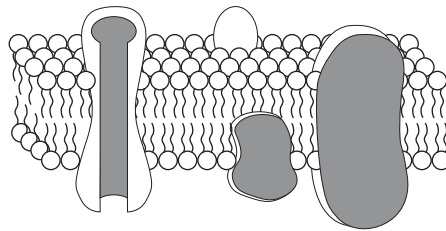

4. *Scenedesmus* is a microscopic, unicellular green alga. However, it often exists as multicellular colonies of cells.



The magnification of the image is 500 \times . What is the length of **one** cell?

- A. 10 nm
 - B. 50 μm
 - C. 20 μm
 - D. 10 mm
5. The diagram shows the product of a polymerization reaction.

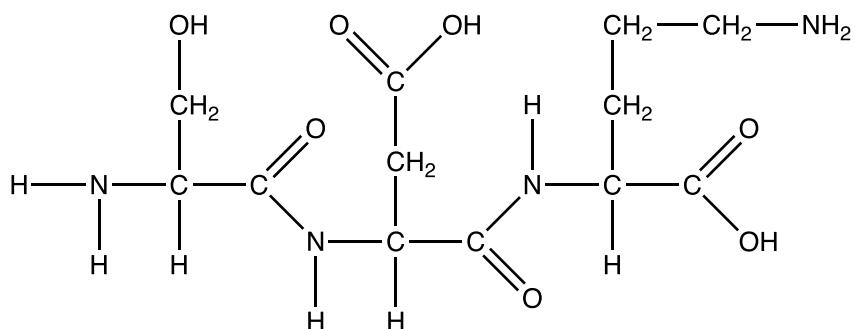

What is formed in this polymerization reaction?

- A. A dipeptide formed by the hydrolysis of two nucleotides
- B. A tripeptide formed by the hydrolysis of three amino acids
- C. A dipeptide formed by the condensation of two amino acids
- D. A tripeptide formed by the condensation of three amino acids

Turn over

6. The activity of amylase from two bacterial species and a fungus was measured at different pH levels and constant temperature. The results are shown in the graph.

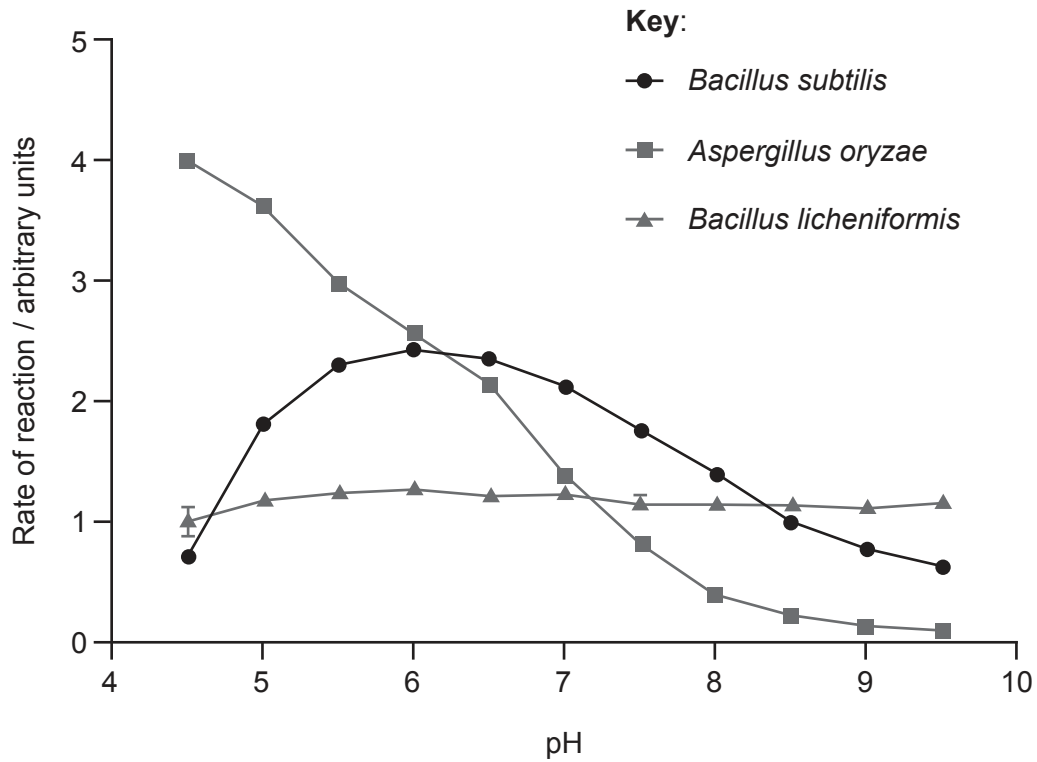

Which statement about the effect of pH on amylase can be concluded?

- A. *A. oryzae* amylase has the highest optimum pH.
- B. A change in pH affects amylase most in *B. licheniformis*.
- C. The optimum pH is 6 in *B. subtilis*.
- D. Amylase activity at pH 8 is the lowest in *B. licheniformis*.

7. What is the arrangement of the components of nucleotides in a single DNA strand?

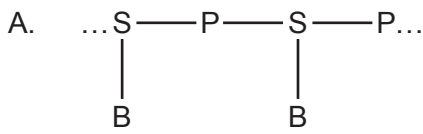

Key:

S – sugar

P – phosphate group

B – organic base

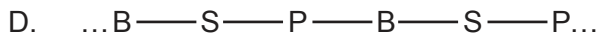
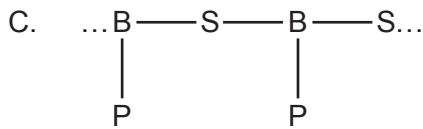
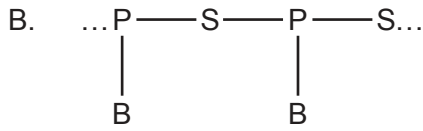

8. The action spectra for two different types of photosynthetic organisms are shown. *Ulva*, or sea lettuce, is a green marine alga composed of two layers of cells. The action spectrum for crop plants was plotted from an average of 22 species of plants.

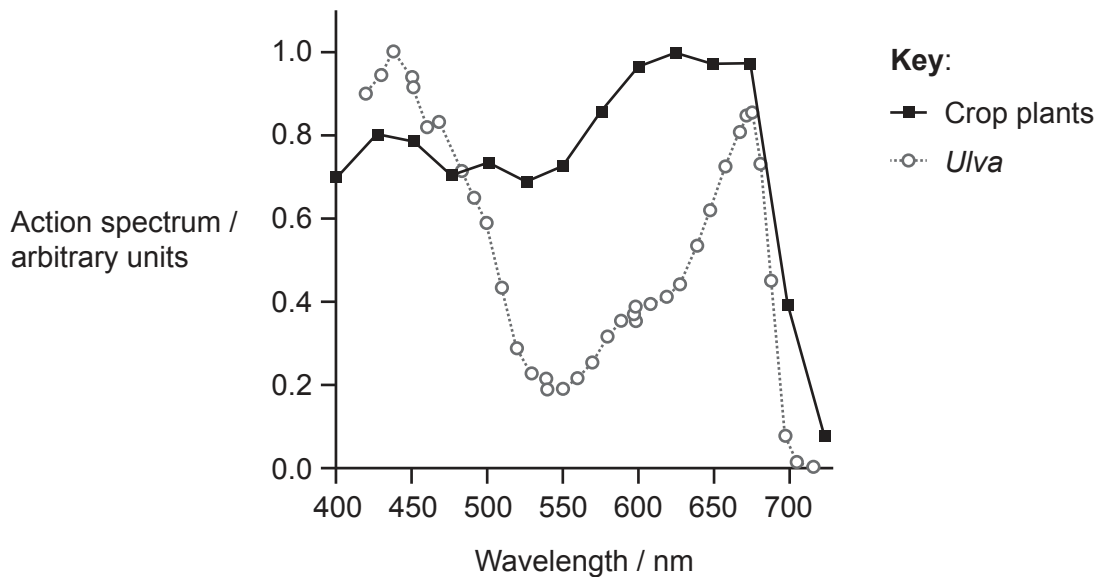

What describes photosynthesis in these organisms?

- A. *Ulva* photosynthesizes more than crop plants at red wavelengths.
- B. Crop plants photosynthesize more than *Ulva* in green light.
- C. Photosynthesis by *Ulva* is highest in red light while that of crop plants is highest in blue.
- D. Both have zero photosynthesis at 750 nm.

Turn over

9. What describes the structure of glycogen?
- A. Unbranched polymer of alpha-D-glucose linked by 1,4 glycosidic linkages
 - B. Branched polymer of alpha-D-glucose linked by 1,6 glycosidic linkages with branches linked by 1,4 glycosidic linkages
 - C. Unbranched polymer of alpha-D-glucose linked by 1,6 glycosidic linkages
 - D. Branched polymer of alpha-D-glucose linked by 1,4 glycosidic linkages with branches linked by 1,6 glycosidic linkages
10. What is a difference between two alleles of a gene?
- A. Their positions on homologous chromosomes
 - B. Their amino acid sequence
 - C. The characteristic they influence
 - D. Their base sequence
11. A couple have four children whose blood groups are A, B and AB. What is the likely combination of the parents' genotypes?
- A. $I^A i$ and $I^B i$
 - B. $I^A i$ and $I^B I^B$
 - C. $I^A I^B$ and ii
 - D. $I^A I^A$ and $I^B I^B$

12. A process for genetically modifying a plant is shown.

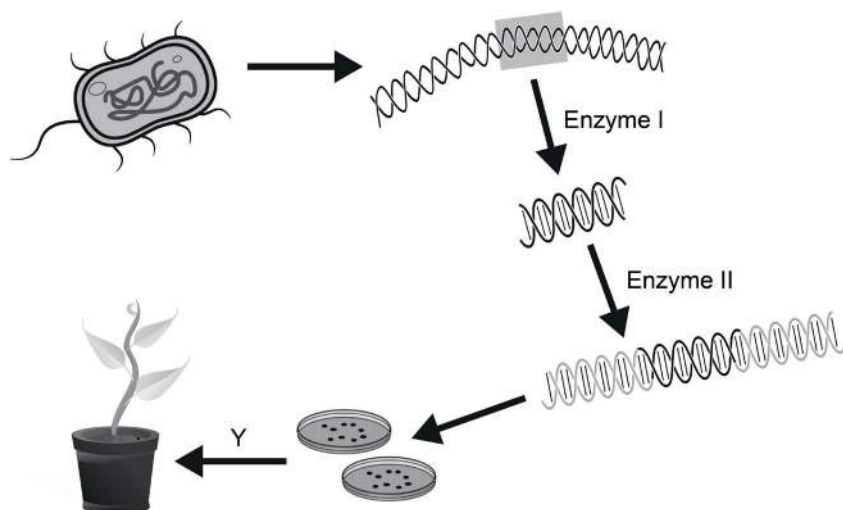

diagram not to scale

What is the name of enzyme II and the name of process Y?

	Enzyme II	Process Y
A.	Helicase	Fertilization
B.	Restriction endonuclease	Tissue culture
C.	RNA polymerase	Fertilization
D.	Ligase	Tissue culture

13. Amniocentesis and chorionic villus sampling (CVS) are used to test for fetal abnormalities. Which statement is a valid comparison between the two tests?

- A. CVS is performed later in pregnancy but has more risk of miscarriage than amniocentesis.
- B. Amniocentesis is performed earlier in pregnancy but has more risk of miscarriage than CVS.
- C. CVS is performed earlier in pregnancy but has more risk of miscarriage than amniocentesis.
- D. Amniocentesis is performed later in pregnancy but has more risk of miscarriage than CVS.

Turn over

14. What is a difference between detritivores and saprotrophs?

	Detritivores	Saprotrophs
A.	Feed on living organic matter	Feed on dead organic matter
B.	Autotrophic	Heterotrophic
C.	Ingest organic matter and then digest it	Digest organic matter and then absorb it
D.	Include fungi and bacteria	Include plants and animals

15. A self-sustaining system is set up in a sterile, sealed, transparent glass bottle with damp, sterilized soil and a small garden plant. If the system remains sterile, what could be the reason that the plant fails to grow and dies?

- A. Lack of soil nutrients
- B. Lack of oxygen
- C. Lack of space
- D. Lack of water

16. The diagram shows part of the carbon cycle involving methane.

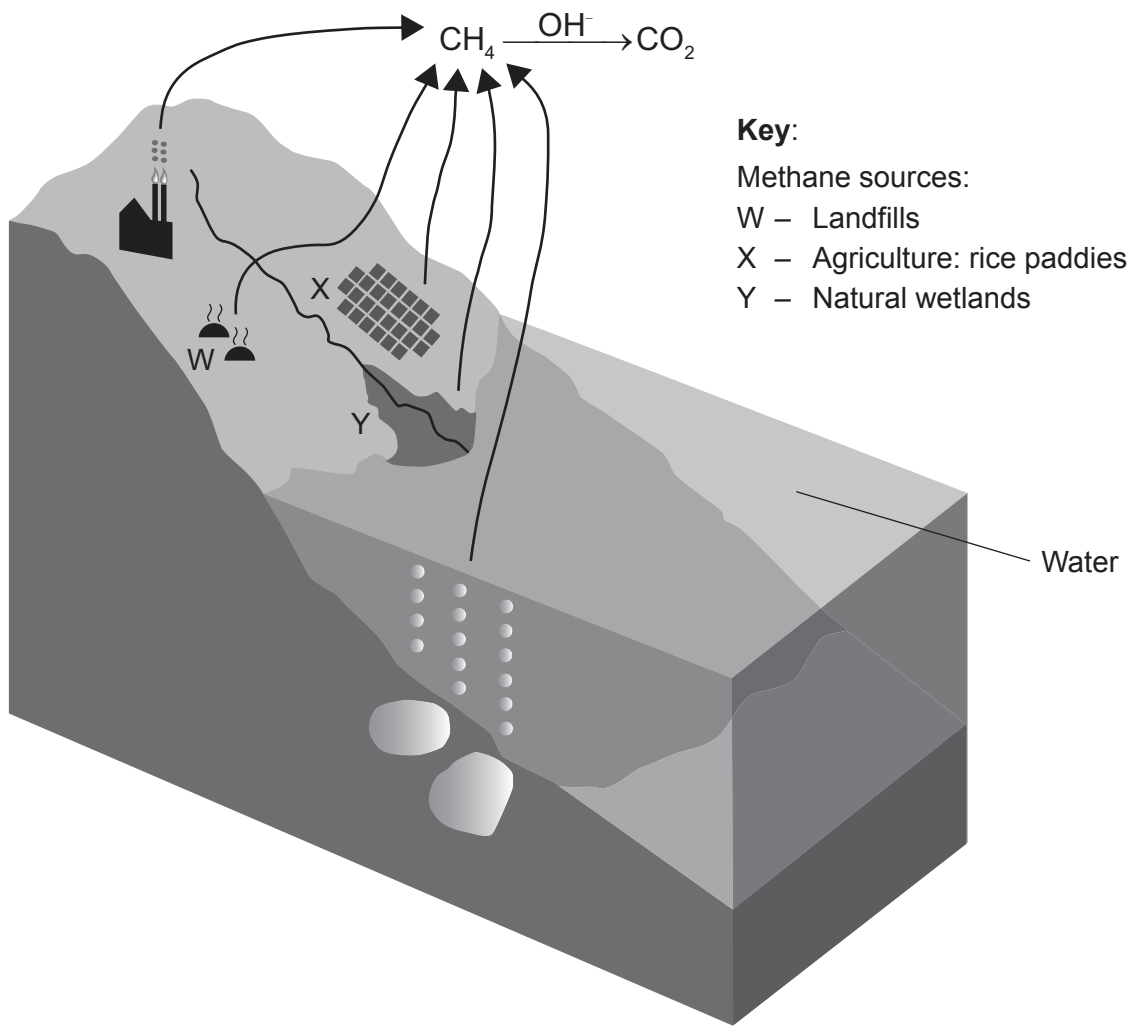

Key:

Methane sources:

W – Landfills

X – Agriculture: rice paddies

Y – Natural wetlands

Which conditions favour methane production in W, X and Y?

- A. Presence of eubacteria and organic matter
 - B. Presence of archaeans and waterlogged soil
 - C. Presence of eubacteria and waterlogged soil
 - D. Presence of archaeans and oxygen
17. By the end of the 19th century in England, the dark form of the moth *Biston betularia* formed up to 98% of the total population in industrial areas. From 1970, the percentage of dark forms decreased significantly. What is an explanation for the decrease?
- A. An increase in environmental pollution killed the dark forms more than the light forms.
 - B. Reduction of pollution resulted in greater camouflage for light forms of the moth.
 - C. Dark forms could no longer find mates.
 - D. Light forms had superior feeding mechanisms.

Turn over

18. The foxglove, *Digitalis purpurea*, was once classified in the figwort family. The figwort family has been reclassified and is now much smaller.



Foxglove



Figwort species

Why were species such as the foxglove moved into other families?

- A. The appearance was too dissimilar.
 - B. The plants are found in different locations.
 - C. The genera were different.
 - D. The DNA sequences indicated different ancestry.
19. What is a recognition feature for both of the plant phyla indicated?

	Filicinophyta	Angiospermophyta
A.	Produce seeds	Produce seeds
B.	Produce spores	Produce flowers
C.	No vascular tissue	Vascular tissue
D.	Vascular tissue	Produce spores

20. The diagram shows a staggered transverse section (cut across rather than down) through the heart.

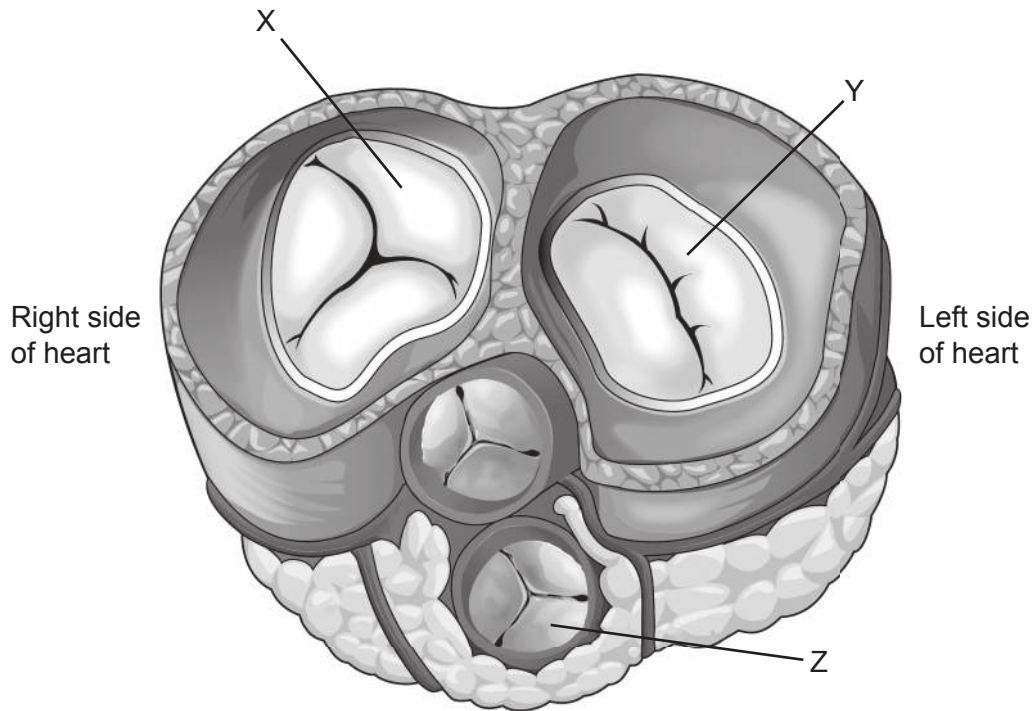

In what state are the valves when the ventricles are contracting?

	X	Y	Z
A.	Open	Closed	Closed
B.	Closed	Closed	Open
C.	Closed	Open	Open
D.	Open	Open	Closed

Turn over

21. Despite continuous scientific research into the control of pathogens, it has proved very difficult to eliminate them. What is/are the reason(s) for this?
- I. Development of antibiotic resistance in viruses
 - II. Development of antibiotic resistance in bacteria
 - III. Mutations of pathogens
- A. II only
 - B. I and II only
 - C. II and III only
 - D. I, II and III

22. The diagram shows a section through an alveolus.

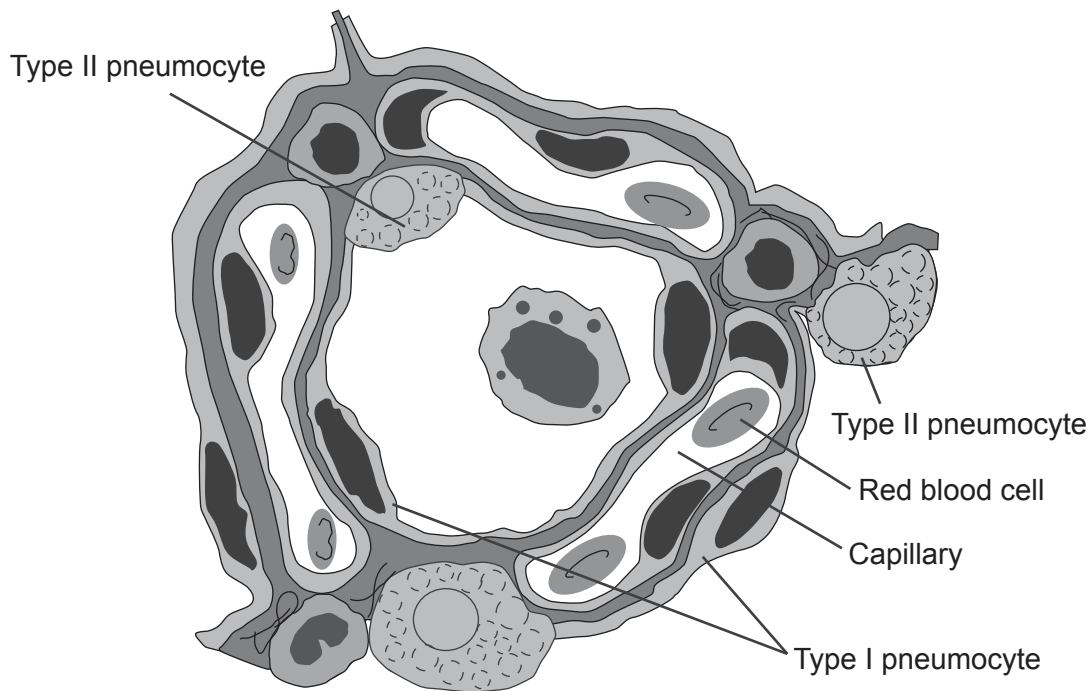

What are the functions of the following labelled structures?

	Type I pneumocyte	Type II pneumocyte	Capillary
A.	Gas exchange	Produces surfactant	Transports carbon dioxide from alveolus
B.	Produces surfactant	Gas exchange	Transports oxygen to alveolus
C.	Gas exchange	Produces surfactant	Transports carbon dioxide to alveolus
D.	Produces surfactant	Gas exchange	Transports oxygen from alveolus

23. Some vaccinations, such as the smallpox vaccine, provide lifelong immunity against the disease. For others, such as tetanus, this immunity lasts for a shorter period of time. Why is a tetanus booster vaccination recommended every 10 years?

- A. Antibodies that formed after the first vaccination persist in the blood for up to 10 years.
- B. Memory cells are not produced after the first vaccination.
- C. Only non-specific immunity is stimulated after the first vaccination.
- D. Memory cells gradually decline over 10 years.

Turn over

24. Atropine drops are used by opticians to dilate the pupil, so that a thorough examination of the retina can be performed. Atropine binds to acetylcholine receptors in synapses.

Normal pupil

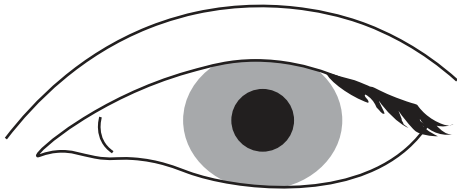

Dilated pupil

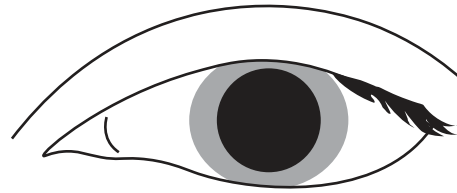

What is the effect of atropine binding in synapses?

- A. Inhibits the binding of acetylcholine at the presynaptic membrane
- B. Inhibits the release of acetylcholine from the presynaptic neuron
- C. Prevents binding of acetylcholine at the postsynaptic membrane
- D. Prevents transport of acetylcholine through the postsynaptic membrane

25. Melatonin controls circadian rhythms and is involved in the sleep-wake cycle. The pineal gland, which secretes melatonin, is inhibited by light. The graph shows a normal cycle where bedtime is around 10pm.

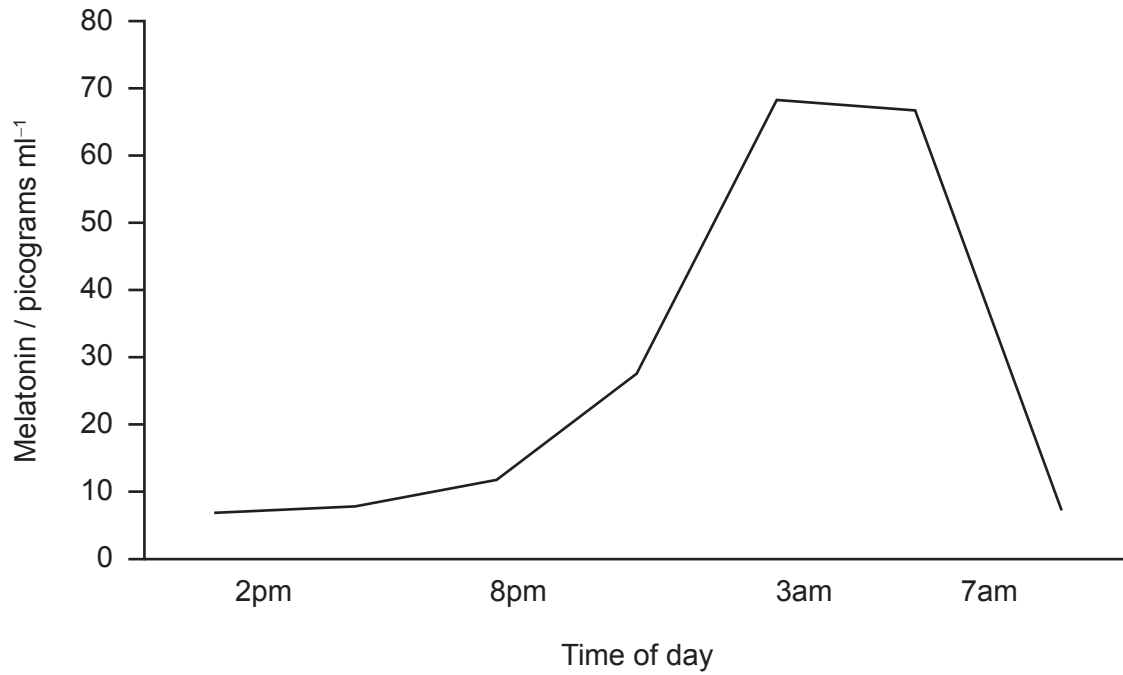

Using data from the graph, what might be the effect(s) of screen light from a laptop, tablet or phone at bedtime?

- I. Delay in melatonin production
 - II. Lower peak concentration of melatonin
 - III. Peak of melatonin earlier in the evening
- A. I only
 - B. III only
 - C. II and III only
 - D. I, II and III

Turn over

26. In transcription, which enzyme has a role similar to that of helicase in replication?
- A. DNA polymerase III
 - B. Gyrase
 - C. RNA polymerase
 - D. DNA polymerase I

27. The diagram illustrates some of the processes involved in DNA replication.

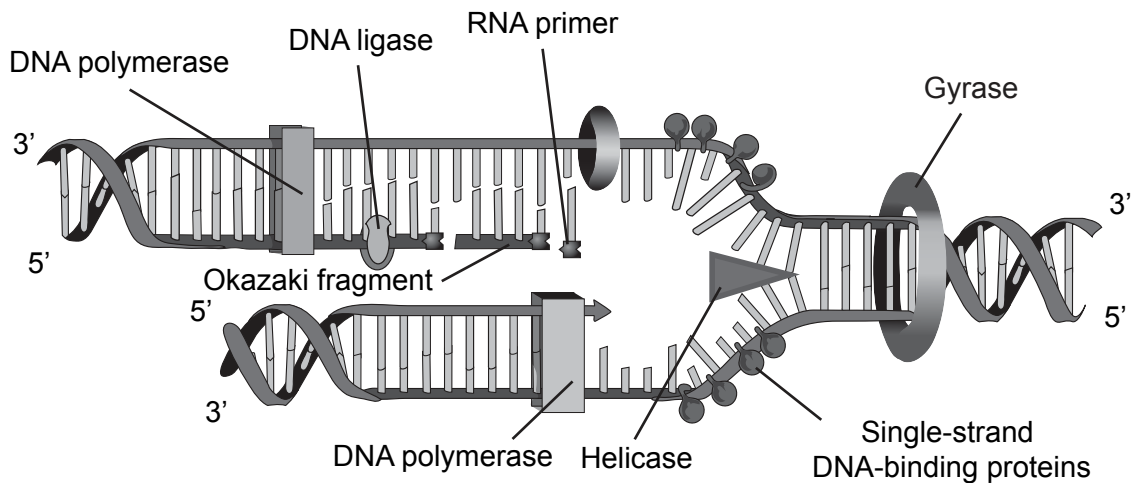

What is shown in the diagram?

- A. DNA polymerase bonding nucleotides in a 3' to 5' direction
- B. Single-stranded DNA-binding proteins on the old strands
- C. Gyrase reforming the double helix
- D. DNA ligase joining Okazaki fragments in the leading strand

28. The diagram shows a ribosome and associated mRNA.

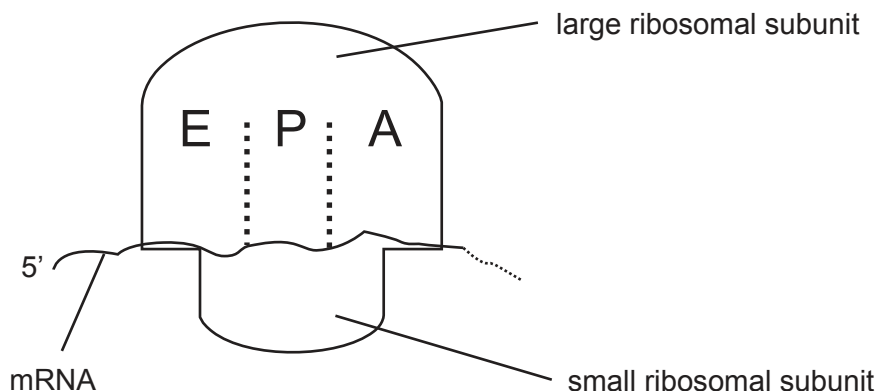

Which of these events occurs first in translation?

- A. Small ribosomal subunit binds to mRNA.
 - B. Large ribosomal subunit binds to mRNA.
 - C. Initiator tRNA enters E site.
 - D. Initiator tRNA enters A site.
29. Antifreeze is a compound called ethylene glycol, which is metabolized in mammals to poisonous compounds that cause kidney failure, amongst other symptoms. The first step in metabolism involves an enzyme called alcohol dehydrogenase. Two inhibitors of this enzyme used in treating antifreeze poisoning are ethanol and fomepizole. The chemical structures of antifreeze and the two inhibitors are shown.

ethylene glycol (antifreeze)

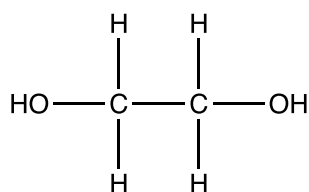

ethanol

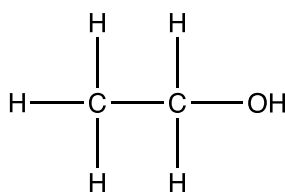

fomepizole

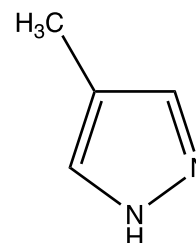

Studies have shown that fomepizole may be preferred to ethanol as a treatment. What is a reason for this?

- A. Fomepizole is a competitive inhibitor and may be given in small doses.
- B. Ethanol is a non-competitive inhibitor and may be given in small doses.
- C. Fomepizole is a non-competitive inhibitor and must be given in very large doses.
- D. Ethanol is a competitive inhibitor and must be given in very large doses.

Turn over

30. An electron micrograph of a mitochondrion is shown.



The distance between the inner and outer membranes, which are shown by the box, is always very small. What is the advantage of this small distance?

- A. Enables a high concentration of electrons to build up quickly
 - B. Enables a high concentration of protons to build up quickly
 - C. Allows fast diffusion of glucose into the mitochondrion
 - D. Allows fast diffusion of reduced NAD out of the mitochondrion
31. What occurs in the light-independent reactions of photosynthesis?
- A. Glycerate 3-phosphate is reduced to triose phosphate.
 - B. Ribulose bisphosphate is regenerated using reduced NADP.
 - C. Ribulose bisphosphate is oxidized to two molecules of glycerate 3-phosphate.
 - D. Both ATP and NADP are used to produce triose phosphate.

32. The apparatus is set up to measure the rate of transpiration. As transpiration occurs from the leafy shoot, water is drawn through the apparatus and is measured by timing the movement of the air bubble along the capillary tube.

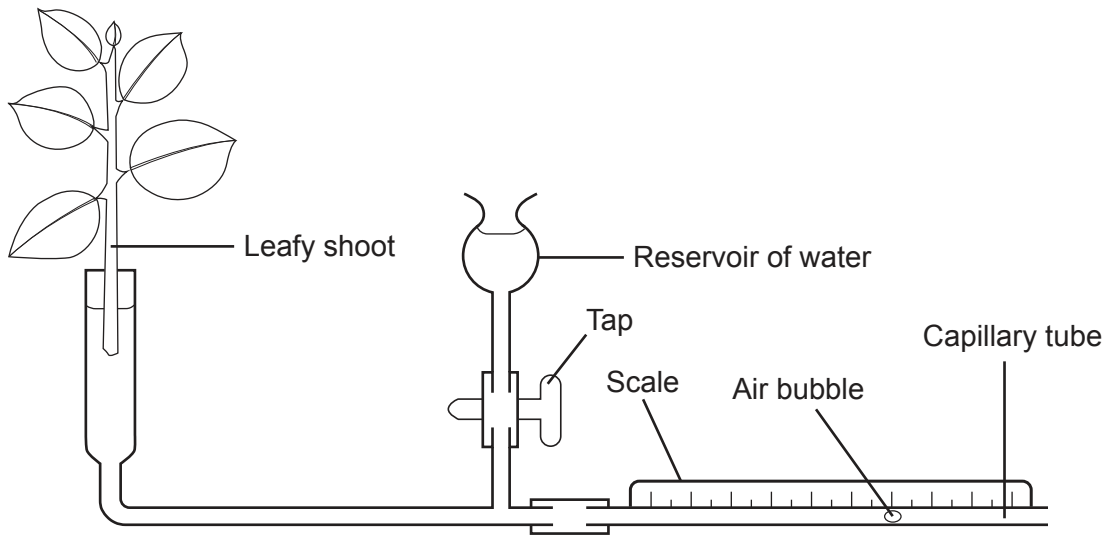

Which variable(s) must be controlled if transpiration rates are compared in different plant species?

- I. Total leaf surface area
 - II. Volume of water in the reservoir
 - III. Room temperature
- A. I only
 - B. III only
 - C. I and III only
 - D. I, II and III
33. Micropropagation is used to produce large numbers of plants in a short period of time. What is a feature of micropropagation?
- A. Any tissue from a plant can be used for micropropagation.
 - B. The plants grown have different variations allowing for adaptations to the environment.
 - C. Micropropagation requires plant pollen and agar gel only.
 - D. The process is sterile and resulting plants are disease-free.

Turn over

34. A hummingbird is shown visiting a large flower.



What makes this a mutualistic relationship?

- A. The bird feeds on nectar and transfers pollen to the stamen of a flower of the same species.
 - B. The bird obtains nutrients and the plant is assisted with pollination for sexual reproduction.
 - C. The bird requires pollen as a protein source and, while obtaining this, disperses seeds for the plant.
 - D. The bird transfers pollen to the stigma of flowers of a different species while feeding.
35. Black, short-haired guinea pigs, heterozygous for both characteristics, were crossed. They produced offspring with the phenotypes black short-haired, black long-haired, white short-haired and white long-haired in the ratio 9:3:3:1. A different cross produced offspring with phenotypes in the ratio 1:1:1:1. What were the genotypes of the parents in the second cross?
- A. $BbSs \times BbSs$
 - B. $BBSs \times BbSS$
 - C. $BbSs \times bbss$
 - D. $bbSS \times BBss$

36. Two kinds of wolf spider rub specialized body parts together in order to produce distinct sounds to attract females. Females of both groups will only allow a male of the same kind to mate with them. It has been found through experimentation, however, that offspring can be produced from crossings between the two groups. What can be hypothesized?

- I. The groups are reproductively isolated.
- II. They could be the same species.
- III. This is an example of behavioural isolation.

- A. I only
- B. II only
- C. I and II only
- D. I, II and III

37. Movement of insects requires muscles in antagonistic pairs. The diagram shows an insect leg with muscles labelled X and Y.

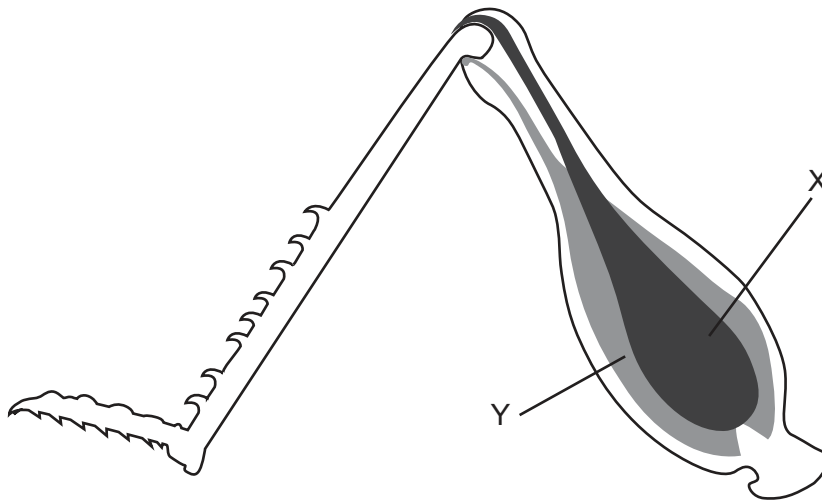

What actions in the human arm are equivalent to muscle X contracting and muscle Y relaxing?

- A. triceps contracts, biceps relaxes, arm extends
- B. biceps contracts, triceps relaxes, arm flexes
- C. triceps contracts, biceps relaxes, arm flexes
- D. biceps contracts, triceps relaxes, arm extends

Turn over

38. A person with failing kidneys is often treated with dialysis several times a week. This is done either by passing blood through a dialysis machine or by using the peritoneum, the lining of the abdomen, as shown in the diagram.

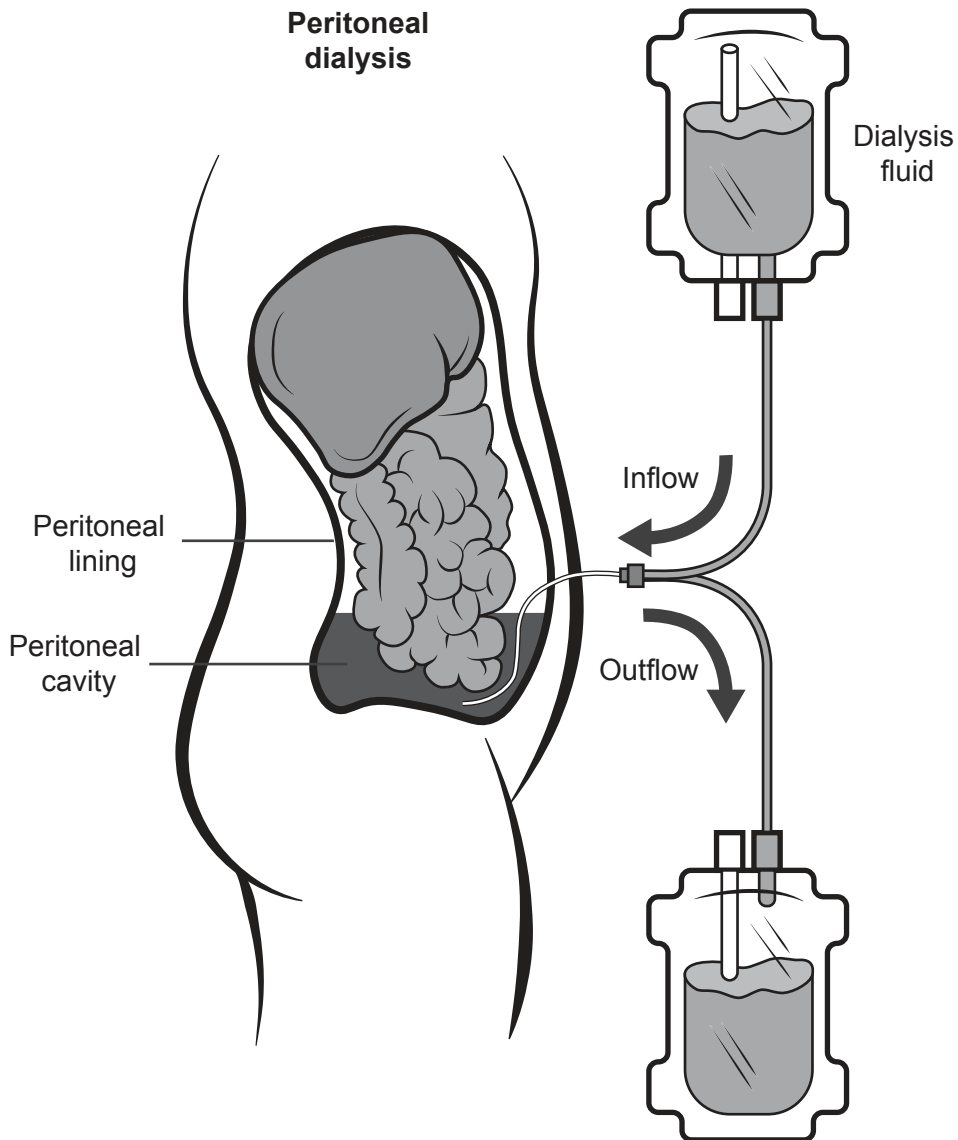

Dialysis fluid is similar to normal blood plasma. What would be in solution in the dialysis fluid?

- A. Sugar, salts and urea
- B. Salts and urea only
- C. Sugar only
- D. Sugar and salts only

39. Which step occurs in **both** spermatogenesis and oogenesis?
- A. First division of meiosis is stopped in prophase I until puberty begins.
 - B. Germinal epithelium cells divide by mitosis.
 - C. At the end of the first division in meiosis, the cytoplasm is divided equally between daughter cells.
 - D. Four haploid gametes are produced at the end of meiosis II.
40. What is the role of HCG in pregnancy?
- A. It is secreted by the embryo to stimulate progesterone secretion by the ovary during early pregnancy.
 - B. Together with oxytocin, it is involved in the positive feedback required for uterine contractions during birth.
 - C. It sustains the secretion of progesterone by the placenta throughout pregnancy.
 - D. It stimulates the ovary to maintain secretion of estrogen in early pregnancy.
-

Disclaimer:

Content used in IB assessments is taken from authentic, third-party sources. The views expressed within them belong to their individual authors and/or publishers and do not necessarily reflect the views of the IB.

References:

1. © Rice University. 1999–2023 *Figure 4.5 Prokaryotic cell*. [image online] Available at: <https://openstax.org/apps/archive/20220815.182343/resources/50163f8ff80f335574f41bfc10cc49a1e87cf9df> [Accessed 13 January 2023].
2. Reischig, J., 2014. [*Onion cells*]. [image online] Available at: [https://commons.wikimedia.org/wiki/File:Mitosis_\(261_14\)_Pressed;_root_meristem_of_onion_\(cells_in_prophase,_anaphase\).jpg](https://commons.wikimedia.org/wiki/File:Mitosis_(261_14)_Pressed;_root_meristem_of_onion_(cells_in_prophase,_anaphase).jpg) [Accessed 27 October 2021].
3. Gorter, E. and Grendel, F., 1925. On bimolecular layers of lipoids on the chromocytes of the blood. *Journal of Experimental Medicine* 41(4), pp. 439–443.
4. www.mikro-foto.de 2010. *Scenedesmus, a green algae*. [image online] Available at: <https://commons.wikimedia.org/wiki/File:Mikrofoto.de-alge2.jpg> [Accessed 13 January 2023]. Source adapted.
6. Held, P., 2012. *Enzymatic Digestion of Polysaccharides. Part II: Optimization of Polymer Digestion and Glucose Production in Microplates*. Available at: <https://www.agilent.com/cs/library/applications/enzymatic-digestion-of-polysaccharides-part-II-5994-3304EN-agilent.pdf>.
16. NASA GISS, n.d. *Rough schematic of methane sources and sinks*. [diagram online] Available at: https://www.giss.nasa.gov/research/features/200409_methane/ [Accessed 26 October 2021].
18. Shiva A., 2008 [image online] Available at: [https://en.wikipedia.org/wiki/File:Purple_Foxglove_\(Digitalis_purpurea\)_2008_02.jpg](https://en.wikipedia.org/wiki/File:Purple_Foxglove_(Digitalis_purpurea)_2008_02.jpg) [Accessed 14 January 2023] CC BY SA 4.0.
Funhoff, D., 2017. *Figwort (Scrophularia canina) flowers, Theisbergstegen, Pfalz, Germany*. [image online] Available at: [https://www.naturepl.com/stock-photo/figwort-\(scrophularia-canina\)-flowers-theisbergstegen-pfalz-germany-june/search/detail-0_01550655.html](https://www.naturepl.com/stock-photo/figwort-(scrophularia-canina)-flowers-theisbergstegen-pfalz-germany-june/search/detail-0_01550655.html) [Accessed 28 October 2021].
20. Oregon State University, n.d. *Heart Anatomy*. [diagram online] Available at: <https://open.oregonstate.edu/aandp/chapter/19-1-heart-anatomy/> [Accessed 28 October 2021].
22. Bergman, Ronald A., Ph.D., and D'Alessandro, Michael P., M.D. Pulmonary alveoli, “Anatomy Atlases”. Available online: <http://www.anatomyatlases.org/> [Accessed 02/01/2023].
27. Rohrmann, G., 2019. *AcMNPV DNA replication*. [diagram online] Available at: <https://www.ncbi.nlm.nih.gov/books/NBK543453/figure/ch05.F1/> [Accessed 26 October 2021].
34. Nussbaumer, R./Naturepl.com, n.d. Black chinned hummingbird (*Archilochus alexandri*). Available at: https://www.naturepl.com/stock-photo/black-chinned-hummingbird-archilochus-alexandri-male-feeding-at-sage-flower/search/detail-0_01140572.html.
37. Johnson, S.K., n.d. [*Insect leg*]. [diagram online] Available at: <http://www.susankjohnson.com/portfolio.shtml> [Accessed 26 October 2021].
39. National Kidney Foundation, n.d. *Peritoneal dialysis*. [diagram online] Available at: <https://www.kidney.org/content/what-peritoneal-dialysis> [Accessed 26 October 2021].

All other texts, graphics and illustrations © International Baccalaureate Organization 2022